

General Operating Instructions

ProMinent® Solenoid Metering Pumps



gamma/ L



delta®

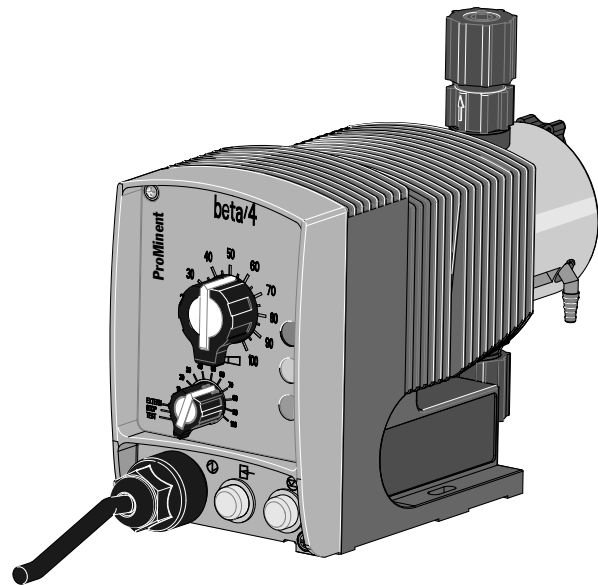

Beta®

Two sets of operating instructions are required for the safe and correct use of the metering pumps:

The product specific operating instructions manual (e. g. for Beta)
and the “ProMinent® Solenoid Metering Pumps General Operating Instructions Manual”.

The two are valid only when read in conjunction with one another.

**Please read through operating instructions manual carefully before use. Do not discard.
The operator shall be liable for any damage caused by installation or operating errors!**

Publishing details

General Operating Instructions ProMinent® Solenoid Metering Pumps
© ProMinent Dosiertechnik GmbH, 2003

Address:
ProMinent Dosiertechnik GmbH
Im Schuhmachergewann 5-11
69123 Heidelberg
Germany
Telefon: 06221 842-0
Fax: 06221 842-617
info@prominent.com
www.prominent.com

We reserve the right to make technical changes.

Table of contents

General instructions for use	4
1 Safety	5
1.1 Identification of the notes on safety	5
1.2 Notes on safety	5
2 Assembly and hydraulic installation	5
2.1 Assembly of the metering pump	6
2.2 Installing hoses	6
2.2.1 Installation of non self-bleeding pumps	6
2.2.2 Installation of self-bleeding pumps (SEK type)	7
2.3 Installation instructions for intake system	8
2.3.1 Notes on the intake side installation	12
2.3.2 Notes on the intake side installation	13
2.3.3 What not to do when installing	13
2.3.4 Special installation instructions	14
3 Commissioning	16
3.1 Set precise metering	18
4 Accessories	19
Appendix	20
Warranty claim form	20
Set-up date form	21
Diagram of system	22
Safety declaration form	23

General instructions for use

Please read the following instructions for use carefully. They will help to get the most use out of the operating instructions manual.

The following are particularly highlighted in the text:

- Numbered points
- ▶ Instructions

Operating instructions:

NOTE

A note provides important notes for the correct functioning of the unit or is to facilitate your work.

Notes on safety identified by pictographs (see Chapter 1).

1 Safety

1.1 Identification of the notes on safety

The following terms are used in the present operating instructions to indicate the various severity levels of the danger:

WARNING

- Characterizes a possibly hazardous situation. Your life is in danger and there is a danger of serious injury if these notes are disregarded!

CAUTION

- Characterizes a possibly hazardous situation. There is a danger of slight or minor injury or damage to property if these notes are disregarded.

The following warning signs are used in the present operating instructions to indicate different types of the danger:



Warning of danger area.

1.2 Notes on safety



WARNING

- Metering pumps can start to operate as soon as they are connected to the mains power supply.
Ensure that no hazardous media can leak out.
If you have not done so, press the Stop/Start button or disconnect the metering pump from the mains immediately.
- The metering pump cannot be switched off.
In the case of an electrical accident, disconnect the power cable from the mains power supply.
- Disconnect the power cable from the mains power supply before working on the metering pump.
- Always depressurise liquid end before working on the metering pump.
- Always empty and rinse the liquid end before working on the metering pump if used with hazardous or unknown feed chemicals.
- Pumps for radioactive media may not be sent by post.



CAUTION

- It is not permitted to assemble and install ProMinent® metering pumps with non-genuine parts which have not been checked and recommended by ProMinent. It can endanger people and property in circumstances for which we are not liable.
- Note the resistances of pump materials when metering aggressive media (see ProMinent® resistance list in the Product Catalogue or at www.prominent.com).
- If fitting a different liquid end size, the pump must be reprogrammed at the factory. The pump delta® can be reprogrammed in the SYSTEM menu.
- Note all national directives which apply to the installation.

2 Assembly and hydraulic installation



WARNING

- The metering pumps must be commissioned precisely in accordance with the instructions in the operating instructions manual.
- Assembly and installation of ProMinent® pumps with non-original parts that have not been checked and recommended by ProMinent.
- Always depressurise lines before working on the metering pump. Empty and rinse out the liquid end.

- Never operate the metering pump against a closed stop valve on the discharge side. The discharge line could rupture.
- Empty any water out of the liquid end upstream before commissioning, or rinse out with a suitable solvent, if you are using media which may not come into contact with water (see p.14, "Dewatering liquid end").
- Note all national directives which apply to the installation.

2.1 Assembly of the metering pump



CAUTION

- Once installed, the metering pump must not vibrate.
- Priming and discharge valves must be vertical (bleed valve in the case of self-bleeding liquid end).
- Ensure easy access for operation and maintenance.

The metering pump must be mounted with the pedestal resting on a firm horizontal surface. (Use screws M5).

2.2 Installing hoses

NOTE

Installation instructions for tubing system, see section 2.3.

2.2.1 Installation of non self-bleeding pumps



CAUTION

- Once fitted, hoses must not be kinked or subject to mechanical stress.
- When metering extremely aggressive or hazardous media we recommend bleeding with return feed into the supply tank and shut off valves on the discharge and intake sides.
- To ensure the durability of the connections, always use correctly-sized circlips and hose nozzles.
- Always use original hoses of the specified diameter and wall thickness.
- Do not exceed the maximum admissible pump priming pressure (see product-specific operating instructions).
- Ensure operating pressure for the metering pump and the tubing system does not exceed the maximum admissible level (see product-specific operating instructions and your system documentation).

NOTE

Fit tubing so that the metering pump and the liquid end can be removed sideways if necessary.

PP, NP, PV, TT versions

Fit hoses to plastic valves (see Fig. 1)

- ▶ Cut ends of hoses straight across
- ▶ Pull the union nut (2) and the circlip (3) over the hose (1)
- ▶ Push the end of the hose (1) over the nozzle (4) as far as the stop, widen if necessary
- ▶ Ensure that the O-ring (5) or flat seal is seated correctly in the valve (6)

NOTE

With the PV design, the FPM flat seal has one point as distinct from the EPDM flat seal.

- ▶ Fit the tubing (1) with the nozzle (4) to the valve (6)
- ▶ Clamp the hose connector:
tighten the union nut (2) while pressing onto the tubing (1)
- ▶ Retighten the hose connector:
pull briefly on the hose (1) connected to the liquid end and tighten the union nut (2) once more.

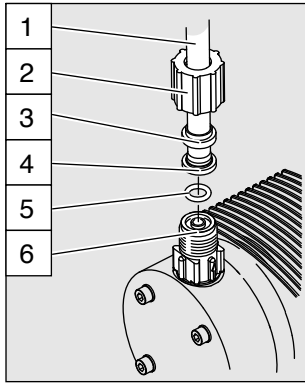

Fig. 1

- 1 Hose
- 2 Union nut
- 3 Circlip
- 4 Nozzle
- 5 O-ring or flat seal
- 6 Valve

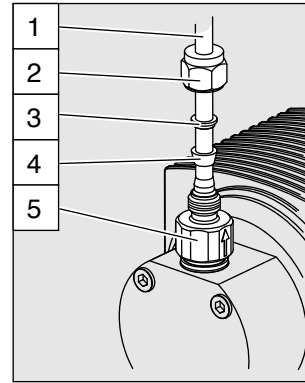

Fig. 2

- 1 Tube
- 2 Union nut
- 3 Rear circlip
- 4 Front circlip
- 5 Valve

SS version

Fit stainless steel pipe connectors to stainless steel valves (see Fig. 2)

- ▶ Push union nuts (2) and circlips (3, 4) approx. 10 mm onto the tube (1)
- ▶ Insert the tube (1) into the valve (5) up to the stop
- ▶ Tighten the union nuts (2).

Fit hoses to stainless steel valves



CAUTION

Fit only PE or PTFE hoses to stainless steel valves.

- ▶ Insert an additional stainless steel reinforcement sleeve into the PE or PTFE hose.

2.2.2 Installation of self-bleeding pumps (SEK type)



CAUTION

- Note all installation and safety instructions for standard pumps.
- Do not exceed maximum values for priming lift, priming pressure and viscosity of the metering medium.
- The intake side tubing cross sections should not exceed the tubing cross section.

A return line is connected as well as the priming and discharge lines. It is attached to the bleed valve to the top of the liquid end (red sleeve, see Fig. 3).

NOTE

The discharge valve in the SEK type is on the front of the liquid end

Installation of the return line

NOTE

In the case of admission pressure on the intake side, the pressure in the return line should be the same or greater.
Admission pressure in the return line limits the bleed function.
It is possible to operate with admission pressure in the return line and atmospheric pressure on the intake side.

- ▶ Attach the hose to the return hose nozzle and/or to the bleed valve of the self-bleeding liquid end (PVC hose, soft, 6x4 recommended)
- ▶ Feed the free end back into the supply tank.
- ▶ Cut the return line so that the end does not reach the feed chemical.

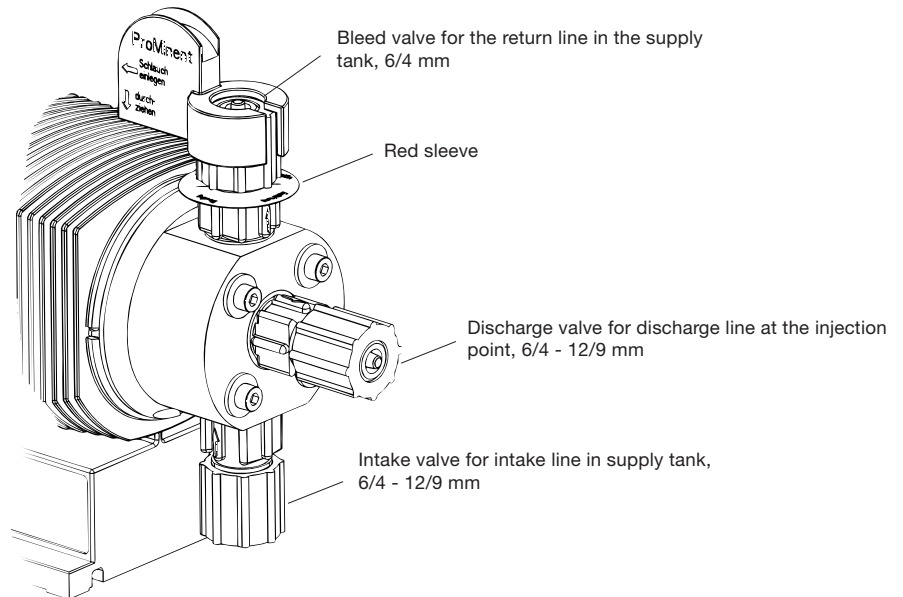

Fig. 3

2.3 Installation instructions for intake system



CAUTION

- Fit a pressure gauge connector to enable checking of the pressure-ratios in the tubing system near the intake connector and of the discharge connector.
- Connect pipes to the pump ensuring that there are no forces exerted on the pump, e.g. movement, weight or line expansion.
Always use a flexible length of tubing to connect steel pipes to plastic liquid ends.

Sample installation

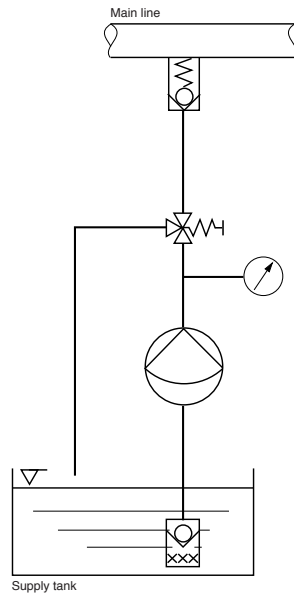













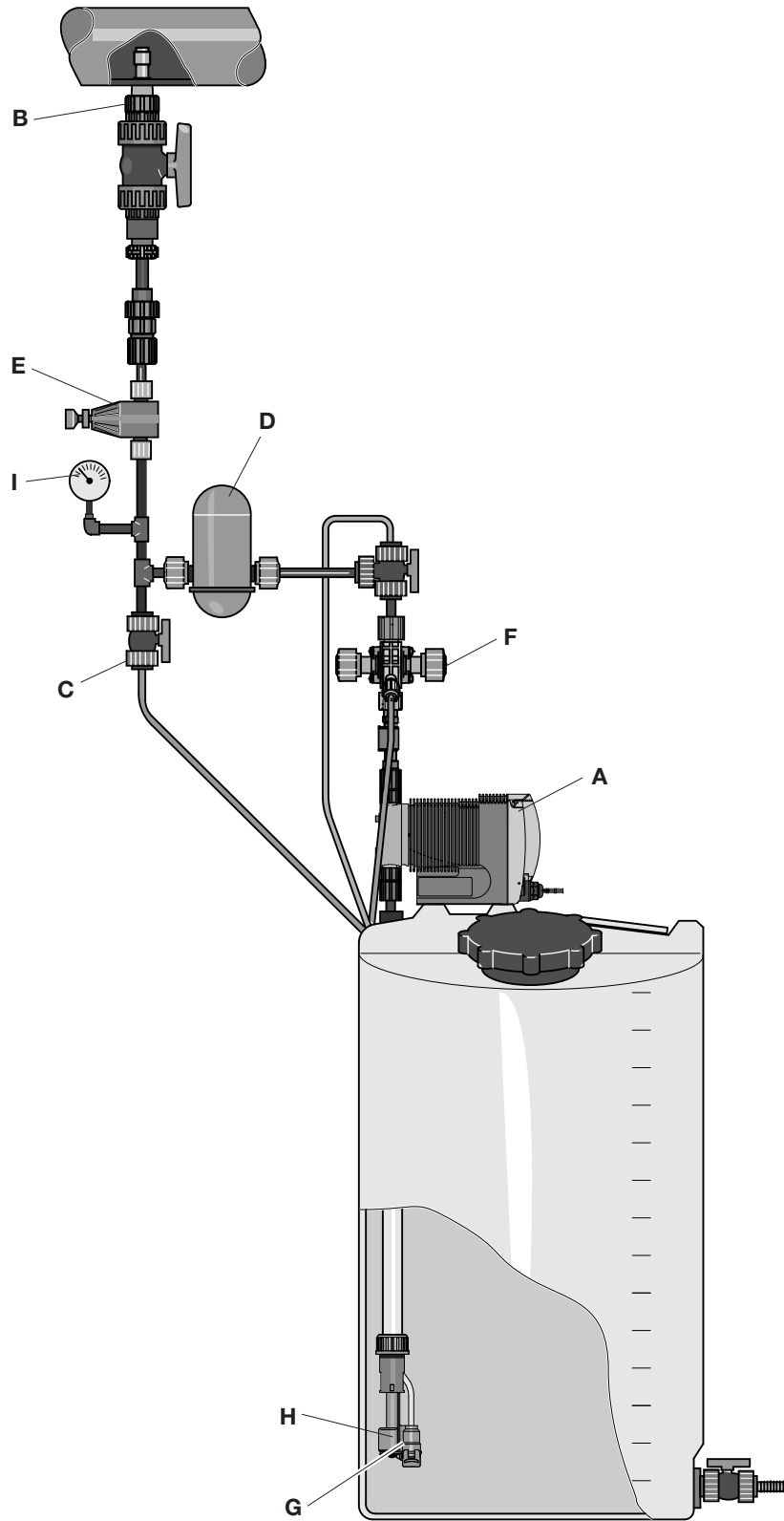

Fig. 4

General key:

- | | | | |
|---|---|---|--------------------------|
|  | Metering pump |  | Foot valve with strainer |
|  | Discharge valve |  | Dirt pan |
|  | Adjustable ball check valve
(also used as pressure relief valve) |  | Float switch |
|  | Multifunction valve |  | Float valve |
|  | Check valve |  | Pressure gauge |
|  | Solenoid valve |  | Filling equipment |
|  | Ball check valve |  | Siphon container |



System components	Function	Application
Metering pump* A	Meters a defined quantity of fluid into a system; Actuation: manual or automatic (external signal)	Variable feed rate and external actuation enables optimum adaptation to metering applications.
Injection valve* B	Non-return valve (return flow impeder) Generates back pressure	... to prevent return flow and mix. in the discharge line in closed tubing systems. ... to create a defined back pressure in tubing system with atmospheric pressure outlet.
Stop valves C	Separate the tubing system into zones (operating zones)	... to stop system parts for aintenance, conversion or repair work.
Pulsation dampener, Accumulator D	Smoothes pulsations in the tubing (discharge side), creates a low pulsation flow	.. to limit pressure loss in long lines. ... to generate a continuous flow/metering. ... to avoid interfering line vibrations.
Ball check valve* E	Generates a defined back pressure (adjustable)	... in the case of intake systems with atmospheric pressure outlet, to guarantee problem-free pump operation. ... when using a pulsation dampener
Multifunction valve* F	Generates a defined back pressure Prevents siphoning Priming aid Relief mechanism for discharge line Opens an overflow line if the preset pressure limit is exceeded	... to guarantee problem-free pump operation in intake system with atmospheric pressure outlet. ... in the case of positive pressure differential between the intake line and the discharge line. ... when commissioning pump against pressure. ...e.g. for repairs ...as safety device to protect the metering system from overload by the metering pump
Pressure relief valve*	Opens an overflow line if the preset pressure limit is exceeded	...as safety device to protect the metering system from overload by the metering pump
Float switch G	Indicates the liquid level in the supply tank (two stage version (with early warning) or single stage)	...for problem-free system operation. ...to indicate that the tank is being changed and/or the supply tank is being topped up. ...to protect the metering system from running empty.
Foot valve* H	Non-return valve (return flow impeder) With integrated sieve as coarse filter empty	... to protect the intake line from running (e. g. when the tank is being changed). ... to protect the metering pump from coarse particles.
Pressure gauge I (gen. pressure meter)	Indicates the prevailing pressure e. g. at the discharge connector of the metering pump	... to detect the prevailing operating pressure in the discharge line. ... essential for adjusting the ball check valve and/or the pressure relief valve.
Vacuum tank	Smooths the pulsations in the tubing (intake side), generates a low pulsation flow Priming aid	... to reduce pressure loss in long intake lines. ... as priming aid with a vacuum pump.
Filter	Filters coarse particles out of the intake flow	... to protect metering pump and equipment from soiling and increased wear and tear.
Solenoid valve	Automation-compatible stop valve Actuation: e.g. electrical, linked to the metering pump power supply	... as safety device to lock (seal) the discharge line when the system is shut down.



CAUTION

* Not absolutely tight seal. Use a stop valve or a solenoid valve for this purpose.

2.3.1 Notes on the intake side installation



CAUTION

- Do not exceed the maximum metering pump admission pressure on the intake side (see product-specific operating instructions manual).
- Always use curved rather than angled joints for bends.
- Never use thin-walled hoses.
- Keep intake line as short as possible.
- The intake line should be rising to prevent air pockets forming.
- Take into account acceleration pressures in long intake lines.
- Height h (see illustration) should not be more than the preset pump suction lift P divided by the density ρ of the feed chemical:

$$h \text{ (in m)} = P \text{ (in mWS)} / \rho \text{ (in g/cm}^3\text{)}.$$

- Measure the cross section and the length so that the vacuum generated by the suction does not reach the vapour pressure of the feed chemical (cavitation Fig. 6). If required, the pump delta® can be adapted to the situation via the METERING menu. Excessive vacuum on the intake side is indicated in extreme cases by an interrupted fluid column or incomplete return stroke.

- Avoid inatking contaminants.

- ▶ e.g. fit a dirt pan (mesh width 100-400 μm depending on the chemical and metering pump type).
- ▶ Always connect intake lines some way above the floor of the tank and/or deposits.

- In the case of slightly gaseous feed chemicals (hydrogen peroxide, chlorine bleach, ...)

- ▶ If necessary have the intake lines falling to prevent sucking in air bubbles (Fig.7)
- ▶ Fit the pump with suction side intake.

NOTE

- Prevent the intake lines from running empty:
Fit a foot valve to the end of the intake lines if the pump is situated higher than the maximum liquid level in the supply tank (Fig. 5):
 - ▶ Cut the free end of the intake line so that the foot valve is suspended just above the base of the tank. In the case of feed chemicals containing contaminants or deposits, make sure that the foot valve is suspended sufficiently high above the tank floor and/or deposit.
- Use a siphon line to prime the pump if using deep tanks with no pipe connector at the base:
 - ▶ Fit filling equipment (Fig. 8) or siphon equipment (Fig. 9) for the siphon line (intake line).

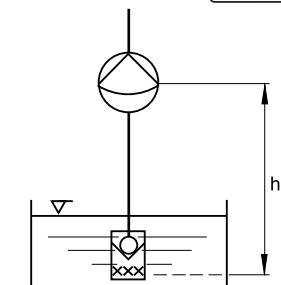

Fig. 5

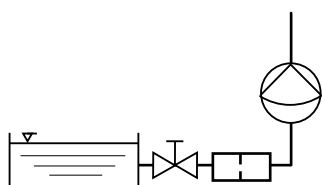

Fig. 6

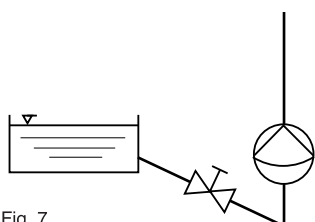

Fig. 7

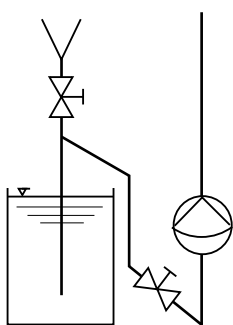

Fig. 8

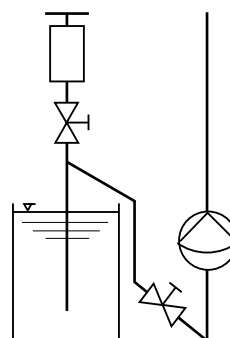

Fig. 9

2.3.2 Notes on the intake side installation

CAUTION

- The maximum admissible operating pressure must not be exceeded by the peak pressures which occur with every metering stroke.
 - ▶ Use a pulsation dampener or fit wider diameter tubing when working with a long discharge line. Read the operating instructions manual for the pulsation dampener carefully when fitting.
 - ▶ A pressure relief valve with a return flow into the supply tank is recommended as an overload protection for the discharge line, e.g. a ProMinent® multifunction valve (Fig. 10).

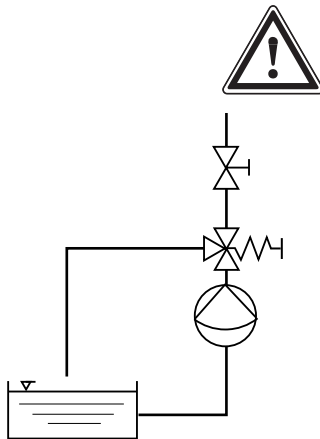

Fig. 10

- Prevent reflux into the main line. This would cause unwanted mixing in the discharge line. Fit a discharge valve to the injection point (Fig. 11).

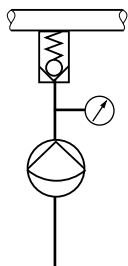

Fig. 11

- Dampen pulsations in the feed flow caused by acceleration forces generated by the tubing dimensions. If required, the pump delta® can be adapted to the situation via the METERING menu.

If acceleration forces are not dampened the result can be:

- cavitation on the intake and discharge sides of the pump leading to feed rate fluctuations, pressure surges, valve knocking and excessive wear and tear
- the maximum admissible operating pressure on the discharge side of the pump being exceeded leading to mechanical damage to the pump, knocking valves and leaks.

2.3.3 What not to do when installing

CAUTION

Avoid the following when installing:

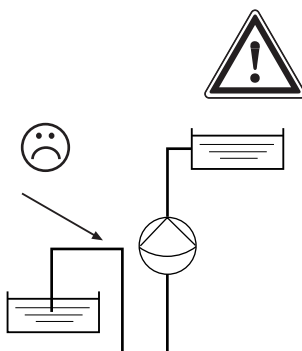

Fig. 12

- Fault: Intake lines cannot be bled
 Cause: Air pocket (arrow) in the intake line
 Remedy: Avoid air pockets or fit as in example 16.

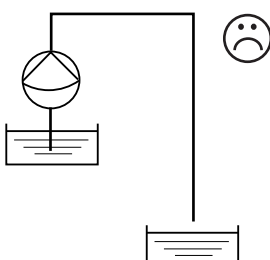

Fig. 13

- Fault: Uncontrolled feed chemical flow when the line is full
 Cause: Siphoning effect caused by discharge line being too low
 Remedy: Interrupt discharge line as in example 17.

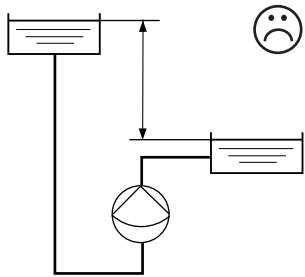

Fig. 14

- Fault:** Feed chemical is being forced through the liquid end
- Cause:** too much pressure suction side admission due to negative pressure differential between discharge and intake
- Remedy:** Fit as in example 17 or 18.

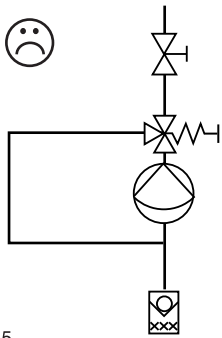

Fig. 15

- Fault:** The intake line can rupture.
- Cause:** The overflow line which can be stopped with a foot valve is feeding back into the intake line.
- Remedy:** Fit as in example 10.
- Fault:** The metering pump is metering the feed chemical in a circuit
- Cause:** The overflow line is feeding back into the intake line and the multifunction valve cannot close again after opening.
- Remedy:** Fit as in example 10.

2.3.4 Special installation instructions



CAUTION

Avoid overfeed caused by positive pressure differential between discharge and intake sides:

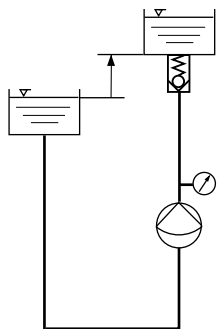

Fig. 16

- Arrange the tubing so that the end of the discharge line is higher than the liquid level in the supply tank

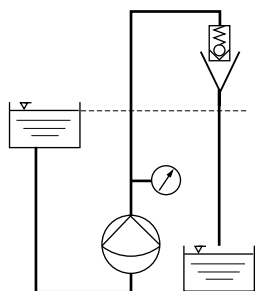

Fig. 17

or:

- Fit the discharge line outlet of the pump so that it is higher than the liquid level in the supply tank

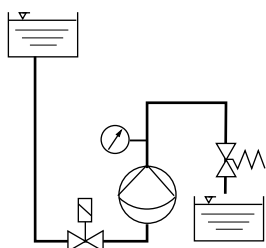

Fig. 18

or:

- Fit an adjustable ball check valve in the discharge line and a check valve in the intake line of the pump - must be closed when the pump is at rest (ideally a solenoid valve).



CAUTION

Changeable pressure-ratios transferred from the extraction line and/or the supply tank to the intake line can lead to uncontrolled pump feed rates. Make sure that the pressure on the intake line remains constant:

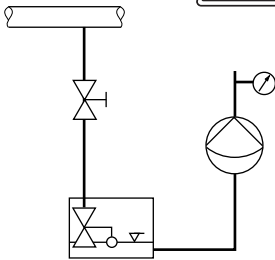

Fig. 19

- If priming from pressurised lines, use an interim tank with a float valve.

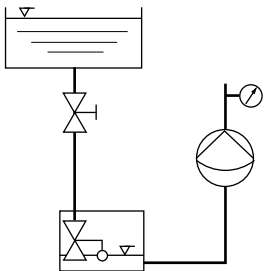

Fig. 20

- If priming from a high intake level, use an interim tank with a float valve.

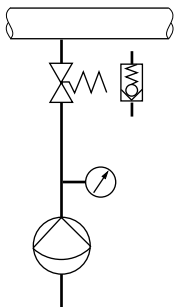

Fig. 21

- Avoid 'through suction' when metering into a main line in which there is a vacuum. Install a multifunction valve, a ball check valve (DHV-RM) or a discharge valve in the discharge line.

Fit a flushing assembly



CAUTION

- The pump must be stopped when flushing is taking place.
- Maximum admissible flushing pressure: 2 bar.

Fit a flushing assembly if metering suspensions (see Product Catalogue section 1.9) to prevent deposits in the liquid end.

There are two flushing principles:

- intermittent flushing (metering is interrupted for rinsing)
- flushing after switching off the pump.

Manually operated flushing assembly

Automatically operated flushing assembly

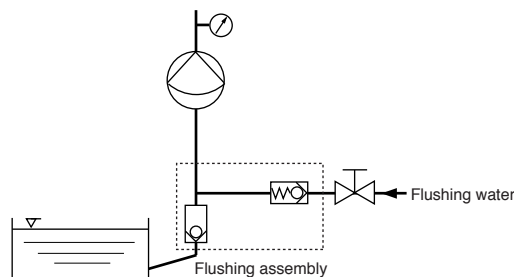

Fig. 22

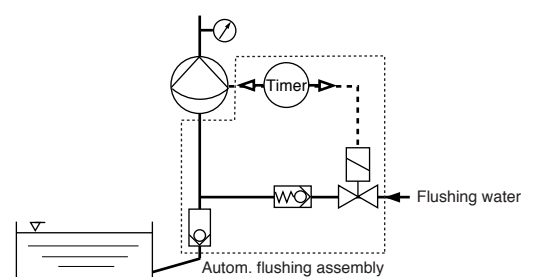

Fig. 23

3 Commissioning



WARNING

- Protect yourself when handling hazardous feed chemicals.
- If using with media which may not come into contact with water, remove all traces from the liquid end before installation. (Procedure, see below. The liquid end may contain traces of water from the factory tests.)
- After long periods out of commission the metering pump cannot be guaranteed to be absolutely reliable as the feed chemical can crystallise in the valves and on the diaphragm. You must carry out regular checks on the valves and the diaphragm (see product-specific operating instructions).
- Check pump connections for tightness.
- Check suction valve and pressure valve for leakages and retighten, if required!
- Check liquid end for leakages and retighten liquid end screw, if required!
- Check that coarse and fine bleed valves are closed are (See also “Fine bleeding”).

NOTE

- Set the stroke length only while the pump is running.
- The metering pump should prime at 100 % stroke length as the priming lift is dependent on the lift volume if the liquid end is empty. If the metering pump has to prime at a lower stroke length and does not do so, select a correspondingly lower priming lift.
- SEK type: The suction lift corresponds to the priming lift because with gaseous media some gas always remains inside the liquid end.
- Retighten liquid end screws after 24 hours in operation).

Screw tightening torque: 4,5 to 5 Nm

Emptying liquid end

Remove all water if working with media which cannot come into contact with water:

- ▶ Rotate the pump until the discharge connector is pointing downwards
- ▶ Let the water run out of the liquid end
- ▶ Blow out from above through the intake connector using suitable equipment or with compressed air.

Filling liquid end



WARNING

Protect yourself when handling hazardous feed chemicals.

In this method, some feed chemical will emerge from the discharge valve.

Liquid ends without coarse/fine bleed valves:

- ▶ Connect the intake line to the liquid end, but not the discharge line
- ▶ Connect a short, transparent hose section to the discharge valve
- ▶ Switch on the metering pump and run at maximum stroke length and stroke rate until the liquid end is full and contains no bubbles (some feed chemical will be visible in the short hose section.)
- ▶ Switch off the metering pump
- ▶ Connect the discharge line to the liquid end.

The metering pump is ready to run.

Liquid ends with coarse/fine bleed valves:

- ▶ Connect the intake and discharge line to the liquid end
- ▶ Connect the return line
- ▶ Open the bleed valve by turning the star knob anti-clockwise; This opens the passage for coarse bleeding via the return line
- ▶ Switch on the metering pump and run at maximum stroke length and stroke rate until the liquid end is full and contains no bubbles (some feed chemical will be visible in the return line or the discharge line)
- ▶ Close the bleed valve (turn clockwise)
- ▶ The metering pump will stop.

The metering pump is ready to run.

NOTE

- **If metering gaseous feed chemicals you should feed a constant partial flow of the metering volume back into the supply tank. The return flow should amount to approx. 20 % of the metering volume.**
- **The feed chemical must be low-viscosity and contain no suspended solids.**
- **The return line should end above the liquid level. The fine bleed valve then acts as a vacuum breaker. This prevents the supply tank from being sucked dry if a vacuum occurs in the discharge line.**

Fine bleeding

In the case of slightly gaseous feed chemicals the liquid end can be continuously bled via the fine bleed valve if equipped with coarse/fine bleeding.

Open fine bleed valve (see Fig. 24):

- ▶ Pull off the knob (A) of the coarse/fine bleed valve (B)
- ▶ Turn the screw (c) in the coarse/fine bleed valve with a screwdriver approx. 1 turn anticlockwise.

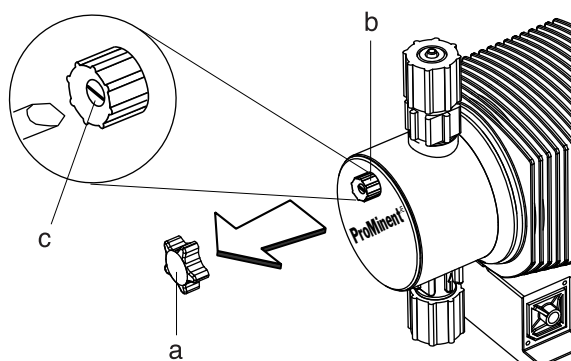

Fig. 24

In the case of self-bleeding metering pumps (SEK type):**NOTE**

The discharge connector on this liquid end is horizontal - the bleed connector is at the top. (The bleed connector is marked with a red band on delivery. (see Fig. 3))

- ▶ Switch on the metering pump and run at maximum stroke length and stroke rate until the liquid end is full and contains no bubbles (some feed chemical will be visible in the return line or the discharge line)
- ▶ Switch off the metering pump.

The metering pump is ready to run.

3.1 Set precise metering

NOTE

- Choose the largest possible stroke length for gaseous media.
- Select the largest possible stroke rate to ensure good mixing.
- For reproducibility in the case of proportional metering set a stroke length of at least 30 % (SEK type: not less than 50 %).

Diagram for setting the feed rate

General notes about stroke length and stroke rate

- ▶ Open at the page with the diagram for your pump type (see product-specific operating instructions manual)
- ▶ Determine the correction factor. Mark the operating pressure for your application in the diagram entitled "Correction factor depending on operating pressure"
- ▶ Trace a vertical line from the defined value up to the curve and then horizontally to the left and read off the correction factor
- ▶ Divide the required feed rate by the defined correction factor and mark this value (l/h) on the "l/h" axis in the diagram entitled "Feed rate depending on stroke length and stroke rate"
- ▶ Trace a horizontal line from this point to the left. Trace another vertical line from the intersections with the straight lines for the variable stroke rate down to the "Stroke length" axis
- ▶ Set the metering pump to one of the stroke rates and the associated stroke length determined in this way.

The measurements for determining the pump capacity for the relevant diagrams have been conducted using water and the stroke length correction factor has been set at 70 %.

4 Accessories



CAUTION

It is not permitted to assemble and install ProMinent® metering pumps with non-genuine parts which have not been checked and recommended by ProMinent. This can endanger people and property in circumstances for which we are not liable.

Float switches

2-stage with 2 m connection cable.

Fault-indicating relay

indicates faults

Fault indicating and pacing relay

indicates faults and supplies pulses for other devices.

Signal cable

Universal-signal 5-core / 2 m, 5 m and 10 m

External contact cable 2-core / 2 m, 5 m and 10 m

Foot valves

with suction filter and non-return valve for connection to end of the intake line.

Discharge valves

with spring-loaded non-return valve for metering in open or closed systems and for attaching discharge line.

Injection lances

for metering into large pipe cross sections and for preventing blockages of crystallising media.

Multifunction valve

for fitting directly to pump head with the following functions:

ball check valve, pressure relief valve, priming aid, relief of discharge line

Back pressure valves

For reproducible metering at low operating pressure or as overflow bypass valve.

Accumulators

for pulsation dampening in the case of e.g. long discharge lines.

Feed monitors

for monitoring the feed rate. After a preset number of un-acknowledged metering strokes a fault is indicated and the metering pump is switched off.

Suction lances

with foot valve and float switch for disposable drums or supply tanks.

Flushing assembly

for flushing and cleaning liquid end, discharge line and discharge valve.
Manual or automatic, timer clock controlled versions.

Supply tank

from 35 to 1000 l capacity with locking screw cap and all necessary accessories.

Manual/electric stirrers

for mixing and batching metering solutions

Consoles

for stable pump assembly.

Warranty claim form

Please copy and send with the pump!
**In the case of failure of the metering pump within the warranty period
please clean the pump
and send it back with a completed warranty claim.**



Please complete in full.

Warranty claim for pump

No.

Company: Phone No.: Date:

Address:

Person responsible (customer):

Order-No.: Delivery-Date:

Pump-type/Identcode: Serial. No.:

Short description of fault

.....

.....

Type of fault

1 Mechanical fault

- Atypical wear and tear
- Consumables
- Breakage/other damage
- Corrosion
- Damage in transit

2 Electrical fault

- Loose connector, e.g. plug or cable
- Controls (e. g. switch)
- Controller

3 Leakage

- Connectors
- Liquid end

4 No feed or poor feed

- Diaphragm faulty
 - Other
-

Application conditions:

Where used/description of equipment:

Accessories used:

.....

.....

Commissioned (Date):

Run-time (approx. operating hours):

Customer:

Project-No.: Date: diagram included:

Pump

Type	-
Feed rate	l/h
Stroke rate	Strokes/min
Stroke length	%
Valve spring pressure, suction side	bar
Valve spring pressure, Discharge side	bar

Medium

Description/concentration	- / % /
Suspended solids content/particle size	% / mm /
Material solid/hardness class	- / (Mohs scale) /
Dynamic viscosity	mPa s (cP)
Density	kg/m ³
Vapour pressure at operating temperature	bar / °C /

Equipment, intake side

Pressure in the suction tank	bar
Set width, intake line	DN / mm /
Suction lift, min./max.	m /
Intake height, min./max.	m /
Length of intake line	m
Number of angles/valves	- / - /
Pulsation dampener	<input type="checkbox"/>	Accumulator with diaphragm ltr.
	<input type="checkbox"/>	Accumulator ltr.

Equipment

Static system pressure, min./max.	bar /
Set width discharge line	DN/mm
Length of discharge line	m
Feed lift	m
Number of angles/valves	- / - /
Pulsation dampener	<input type="checkbox"/>	Accumulator with diaphragm ltr.
	<input type="checkbox"/>	Accumulator ltr.

Diagram of system

Customer:

Project-No.: Date:

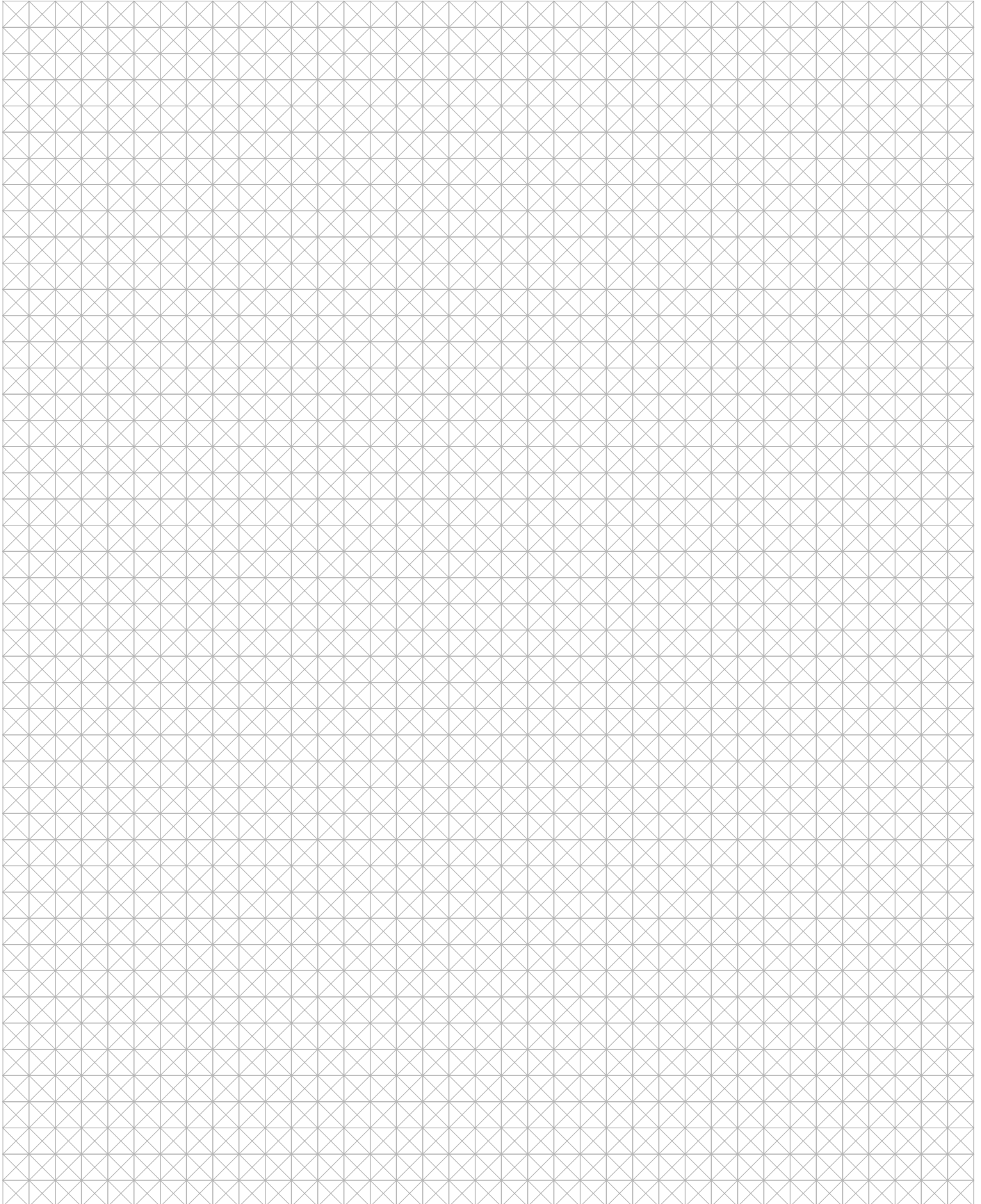

Safety declaration form

**A completed form must always be returned with the equipment!
This declaration must only be completed and signed by an authorized member of the technical staff!**

The equipment or its parts will only be repaired or serviced if it is accompanied by a correctly completed and signed safety declaration form. The work could be delayed if no form is returned.

Legally binding declaration

We hereby assure that:

1. The enclosed equipment

Type: _____

Serial No.: _____

is free from any

- toxic
- corrosive
- microbiological
- carcinogenic
- explosive
- radioactive substances
- or other substances that may be harmful to health.

2. The equipment was thoroughly cleaned before being shipped.

3. There is no hazard due to residual contamination.

4. The details given in this form are correct and complete.

Company / Institute: _____

Street: _____

Postcode, Town: _____

Tel: _____

Fax: _____

Surname, First name: _____

Position: _____

Date: _____

Legally binding signature

Company stamp

Die ProMinent Firmengruppe / The ProMinent Group

Stammhaus / Head office

ProMinent Dosiertechnik GmbH · Im Schuhmachergewann 5-11 · 69123 Heidelberg · Germany
 info@prominent.com · www.prominent.com · Tel.: +49 6221 842-0 · Fax: +49 6221 842-617

Tochtergesellschaften / Subsidiaries

ProMinent Fluid Controls Pty. Ltd. **(Australia)**
 Tel.: +61 2 94500995
 sales@prominentfluid.com.au
 www.prominentfluid.com.au

ProMinent Dosiertechnik Ges. mbH **(Austria)**
 Tel.: +43 7448 30400
 office@prominent.at
 www.prominent.at

ProMinent Fluid Controls (Bangladesh) Ltd. **(Bangladesh)**
 Tel.: +8802 8319047
 info@prominent-bd.com
 www.prominent-bd.com

ProMinent Belgium S.A., N.V. **(Belgium)**
 Tel.: +32 2 3914280
 info@prominent.be

ProMinent Brasil Ltda. **(Brazil)**
 Tel.: +55 11 43610722
 prominent@prominent.com.br
 www.prominent.br

ProMinent Fluid Controls BG **(Bulgaria)**
 Tel.: +359 2 9631921
 prominent@abv.bg

ProMinent Fluid Controls Ltd. **(Canada)**
 Tel.: +1 519 8365692
 info@prominent.ca
 www.prominent.ca

ProMinent Fluid Controls China Co. Ltd. **(P.R. of China)**
 Tel.: +86 411 87315738
 dr.r.hou@prominent.com.cn
 www.prominent.com.cn

ProMinent Bermat S.A. **(Chile)**
 Tel.: +56 2 3354 799
 slagos@prominentbermat.cl
 www.prominetbermat.de

ProMinent Dosiertechnik CS s.r.o. **(Czech Republ.)**
 Tel.: +420 585 757011
 info@prominent.cz
 www.prominent.cz

ProMinent Finland OY **(Finland)**
 Tel.: +35 89 4777890
 prominent@prominentfinland.fi

ProMinent France S.A. **(France)**
 Tel.: +33 3 88101510
 contact@prominent.fr
 www.prominent.fr

ProMinent ProMaqua GmbH **(Germany)**
 Tel.: +49 6221 6489-0
 info@promaqua.com
 www.promaqua.com

ProMinent Fluid Controls (UK) Ltd. **(Great Britain)**
 Tel.: +44 1530 560555
 sales@prominent.co.uk
 www.prominent.co.uk

ProMinent Hellas Ltd. **(Greece)**
 Tel.: +30 210 5134621
 info@prominent.gr

ProMinent Magyarorszag Kft. **(Hungary)**
 Tel.: +36 96 511400
 prominent@prominent.hu
 www.prominent.hu

Heidelberg ProMinent Fluid Controls India Pvt. Ltd. **(India)**
 Tel.: +91 80 23578872
 prominent@hpfccindia.com
 www.prominentindia.com

ProMinent Fluid Controls Ltd. **(Ireland)**
 Tel.: +353 71 9151222
 info@prominent.ie

ProMinent Italiana S.R.L. **(Italy)**
 Tel.: +39 0471 920000
 info@prominent.it
 www.prominent.it

ProMinent Japan Ltd. **(Japan)**
 Tel.: +81 35812 7831
 info@prominent.co.jp

ProMinent Korea Co. Ltd. **(Republic of Korea)**
 Tel.: +82 31 7018353
 info@prominent.co.kr
 www.prominent.co.kr

ProMinent Office Kazakhstan **(Kazakhstan)**
 Tel.: +7 3272 504130
 prominent@ducatmail.kz

ProMinent Office Kaunas **(Lithuania)**
 Tel.: +370 37 325115
 prominent1@takas.lt

ProMinent Fluid Controls (M) Sdn. Bhd. **(Malaysia)**
 Tel.: +603-806 825 78
 info@pfc-prominent.com.my
 www.pfc-prominent.com.my

ProMinent Fluid Controls Ltd. **(Malta)**
 Tel.: +356 21693677
 info@pfc.com.mt

ProMinent Fluid Controls de México, S.A. de C.V. **(Mexico)**
 Tel.: +52 (442) 2189920
 venfas@prominent.com.mx

ProMinent Verder B.V. **(Netherlands)**
 Tel.: +31 30 6779280
 info@prominent.nl
 www.prominent.nl

ProMinent Dozotechnika Sp. z o.o. **(Poland)**
 Tel.: +48 71 3980600
 info@prominent.pl

ProMinent Portugal Controllo de Fluidos, Lda. **(Portugal)**
 Tel.: +35 121 9267040
 geral@prominent.pt
 www.prominent.pt

ProMinent Dositehnika OOO **(Russia)**
 Tel.: +7 095 7874501
 info@prominent.ru

Proshield Ltd. **(Scotland)**
 Tel.: +44 1698 260260
 pcp@proshield.co.uk
 www.proshield.co.uk

ProMinent Fluid Controls (Far East) Pte. Ltd. **(Singapore)**
 Tel.: +65 67474935
 pfc@prominent.com.sg

ProMinent Slovensko s.r.o. **(Slovak. Republ.)**
 Tel.: +421 2 48200111
 prominent@prominent.sk
 www.prominent.sk

ProMinent Fluid Controls Pty. Ltd. **(South Africa)**
 Tel.: +27 11 8254142
 promsa@mweb.co.za

ProMinent Gugal S.A. **(Spain)**
 Tel.: +34 972 287011/12
 prominent@prominentSpain.com
 www.prominent.es

ProMinent Doserteknik AB **(Sweden)**
 Tel.: +46 31 656600
 info@prominent.se
 www.prominent.se

Tomal AB **(Sweden)**
 Tel.: +46 (0) 346-713100
 info@tomal.se
 www.tomal.se

ProMinent Dosiertechnik AG **(Switzerland)**
 Tel.: +41 44 8706111
 info@prominent.ch
 www.prominent.ch

ProMinent Fluid Controls (Taiwan) Ltd. **(Taiwan)**
 Tel.: +886 7 8135122
 richard@prominent.com.tw
 www.prominent.com.tw

ProMinent Fluid Controls (Thailand) Co. Ltd. **(Thailand)**
 Tel.: +66 2 3760008
 pfc@prominent.co.th
 www.prominent.co.th

ProMinent Office Kiev **(Ukraine)**
 Tel.: +380 44576 1855
 prominent@i.com.ua

ProMinent Fluid Controls, Inc. **(USA)**
 Tel.: +1 412 7872484
 sales@prominent.cc.us
 www.prominent.us

ProMinent Juffcii FZC **(VAE)**
 Tel.: +97 1655 72626
 a.sadaga@prominentfzc.ae

Vertretungen weltweit / Distributors Worldwide

Argentina · Bahrain · Bolivia · Botswana · Chile · Columbia · Costa Rica · Croatia · Cuba · Cyprus · Denmark · Egypt · El Salvador · Guatemala · Hong Kong · Indonesia · Iceland · Iran · Ireland · Israel · Jordan · Kenya · Kuwait · Macedonia · Malta · Namibia · New Zealand · Nigeria · Norway · Oman · Pakistan · Panama · Paraguay · Peru · Philippines · Qatar · Romania · Russia-Ural Region · Saudi Arabia · Senegal · Serbia/Montenegro · Slovenia · Sudan · Syria · Tanzania · Tunisia · Turkey · Turkmenistan · Uganda · Uruguay · United Arab Emirates · Venezuela · Vietnam · White Russia · Zimbabwe

Anschriftennachweise erhalten Sie durch: / Addresses of distributors are available from: ProMinent Dosiertechnik GmbH, Germany